

# Aspect™ High-Tilt

## Imaging Table Datasheet

Ideal C-arm imaging solution for:

- Swallowing studies in post-surgical banding adjustment
- C-arm procedures requiring upright patient imaging or loading



### Features

- Motorized tilt from horizontal to 75° upright with footswitch operator control
- Vertical motion is synchronized with tilt to maintain patient position during articulation. When level, the table top height is fixed at 32"
- Step-on patient loading with table in upright position
- 525 lb. patient weight capacity
- Ultra-stable during tilt motion and in any table position
- Easy C-arm imaging access in any tabletop position
- Compact table pedestal = very large imaging area
- Carbon fiber tabletop: artifact-free, low x-ray attenuation
- Standard 110 volt operation with battery back-up
- 5" locking casters and lightweight table for easy transport

### Table includes:

- Built-in footboard
- Patient hand grips
- Footswitch control
- Tabletop pad
- Restraint straps

**idi**  
Image Diagnostics, Inc.  
*Safety, Simplicity, Quality*

# Aspect™ High-Tilt Product Specifications

## Table dimensions:

- Tabletop: 24" W x 80" L (61cm x 203 cm)
- Table height in horizontal position: 32" (81cm) Fixed height  
Footboard position with table upright: 5' (12.7cm) above floor

## Imaging area:

- ~55" L (140cm) x 24" W (61cm)

## Tilt movements:

- Table tilt range: 0° (horizontal) to 75° upright
- Motorized tilt via foot switch control
- Tilt speed: ~4°/sec (~20 sec to full stroke)

## Patient weight capacity:

- 525 lb. (238kg)

## Electrical:

- 110 VAC with battery backup (230 VAC operation optional)
- 

## Table Weight:

- Table: ~605 lbs. (274 kg)

## Accessories included:

- Tabletop Pad, 1" thick
- Hand grips (2)
- Standard US side rails (3/3" x 1 1/8") for hand grips attachment
- Footswitch control
- Patient Restraint Straps (2)

## Optional Accessories (not included in standard accessory package):

- 2" thick pad

## Warranty: 3 years parts, 1 year labor

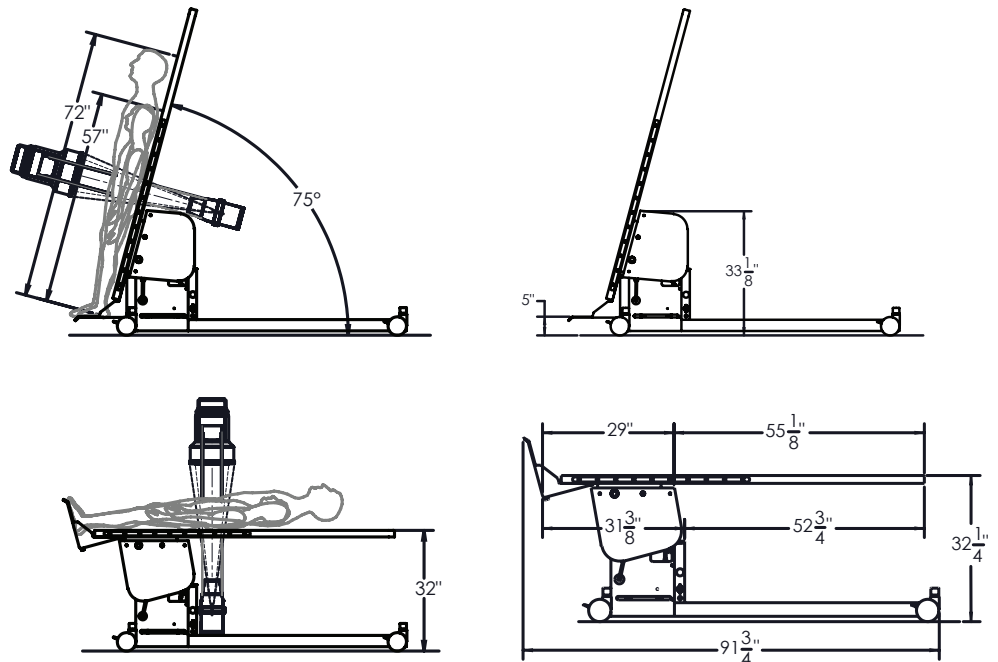

## Image Diagnostics

Since 1986, IDI has been a manufacturer of innovative products for surgical, interventional and diagnostic imaging.

Our product focus is in electro-mechanical solutions for fluoroscopic and digital radiographic applications.

IDI is committed to superior product design, value and customer support in everything we do.

**Image Diagnostics, Inc.**  
310 Authority Drive  
Fitchburg, MA, 01420  
USA

Toll free: 877-304-5434  
Tel: 978-829-0009  
Fax: 978-829-0027  
www.imagediagnostics.com



Certifications: ETL listed to UL 2601-1,  
UL 60601-1, EN 60601-1, IEC 60601-2-32,  
IEC 60601-2-46 certification