

EC Series

Blanket Warming Cabinet



EC250



EC350
Shown with optional
plate & casters



EC750
Shown with optional
window door, lock, and
left hinged door

- Energy efficient WarmSafe™ heating system monitors interior surface temperatures and balances heat throughout cabinet
(Patent No: US 8,217,316; US 8,581,152)
- Silent operation (no fans or moving parts)
- Lint traps not required
- Stationary or mobile option
- Epoxy-coated interior surfaces
- Programmable control
- Three capacities available:
 - » 4-6 blankets (2.5ft³)
 - » 10-12 blankets (3.5ft³)
 - » 20-25 blankets (7.5ft³)

EC Series Blanket Warming Cabinet

Specifications:

- Single-chamber warming cabinet.
- Stainless steel exterior and white epoxy-coated interior insert.
- Door is fully gasketed with a magnetic closure.
- WarmSafe™ heating system incorporates a multiple zone warming technology (*Patent No: US 8,217,316; US 8,581,152*) that heats where and when it is needed. All chamber surface temperatures are monitored, providing an efficient balance of heat, low energy consumption and minimal heat loss.
- EC350 & EC750 include a heated center shelf to further optimize heat distribution throughout the cavity.
- Four (4) non-skid rubber feet are standard.

Control:

- Adjustable temperature range of 32° - 71°C (90° - 160°F).
- Operates in Celsius or Fahrenheit.
- Four digit L.E.D. display.
- On/off button.
- Up and down adjustment buttons.
- Actual temperature button.
- Built-in speaker for audible feedback.
- Integrated button lock-out feature.

Additional features:

- Safety: In the event of a power failure the cabinet will remember its programming and begins to operate as before when power is restored.
- Safety: A warming shut-off system, separate from the electronic control, prevents overheating.
- Convenience: Access point and removable cover have been added to the back panel that allows the addition of data logging or temperature management hardware.

Clearance requirements:

3" (76mm) from rear
1" (25mm) from top and sides
3/4" (19mm) from bottom

Options & Accessories – Specify at time of order

Bumper & Caster Assembly, 3" (76mm) CASTERS (2 RIGID, 2 SWIVEL W/BRAKE);
OVERALL HEIGHT INCREASES BY 5" (127mm)

- EC250 or EC350 – 5017548
- EC750 – 5017549
- EC750/PT – 5018180

Caster Package with Plate, 3" (76mm) CASTERS (2 RIGID, 2 SWIVEL W/BRAKE);
OVERALL HEIGHT INCREASES BY 5" (127mm)

- EC250 or EC350 – 5017544
- EC750 – 5017545
- EC750/PT – 5018124

Caster Package, 3" (76mm) CASTERS (4 SWIVEL W/BRAKE);
OVERALL HEIGHT INCREASES BY 4.3" (109mm)

- EC250 or EC350 – 5012693

Caster Package, 5" (127mm) CASTERS (4 SWIVEL W/BRAKE);
OVERALL HEIGHT INCREASES BY 6.5" (165mm)

- EC750 – 5018646
- EC750/PT – 5018647

Door, Right Hinged

- Solid door without manual door lock (STANDARD)
- Solid door with manual door lock (OPTIONAL)
- Windowed door without manual door lock (OPTIONAL)
- Windowed door with manual door lock (OPTIONAL)

Door, Left Hinged

- Solid door without manual door lock (OPTIONAL)
- Solid door with manual door lock (OPTIONAL)
- Windowed door without manual door lock (OPTIONAL)
- Windowed door with manual door lock (OPTIONAL)

Pass-through (EASILY ACCESS BLANKETS FROM THE FRONT AND BACK DOOR)

- EC750/PT

Seismic Mounting Brackets (SPECIAL INSTALLATION REQUIREMENTS APPLY)

- Contact Factory

Stacking Kits (IT IS RECOMMENDED THAT FLUID WARMING UNITS BE PLACED AT OR NEAR THE BOTTOM OF THE STACKED CONFIGURATION WHENEVER POSSIBLE FOR MAXIMUM STABILITY.)

- EC250 or EC350 over EC250 or EC350 – 5017272
- EC250 or EC350 triple stacked – 5017539

EC250

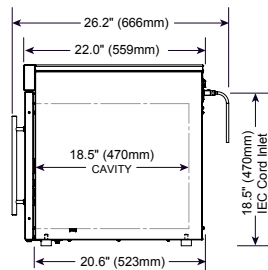
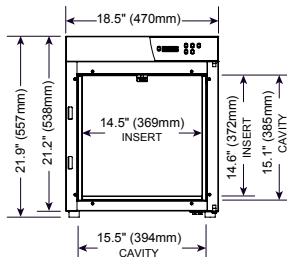
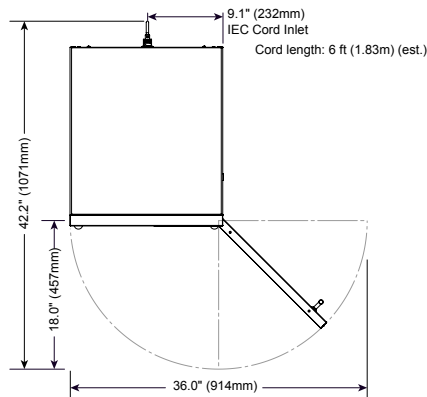

Dimensions (HxWxD)

With feet (STANDARD):	21.9" x 18.5" x 26.2" (557mm x 470mm x 666mm)
With casters & plate (OPTIONAL):	26.2" x 18.5" x 26.2" (666mm x 470mm x 666mm)
With bumper and casters (OPTIONAL):	26.2" x 21.3" x 26.5" (666mm x 540mm x 673mm)
With casters (OPTIONAL):	25.5" x 18.5" x 26.2" (647mm x 470mm x 666mm)

Capacity 2.5 ft³

Weight (est.)** NET 67 lbs (30 kg) SHIP, CRATED 135 lbs (62 kg)

Electrical

120 V.A.C. — 60 Hz, 1 ph
0.6 kW, 5.0 Amps
Safety Class I Equipment
No Applied Parts
Mode of Operation: Continuous



NEMA 5-15P
15A - 125V Plug
Hospital Grade



220 V.A.C. — 60 Hz, 1 ph
0.6 kW, 2.7 Amps
Type B Equipment



CEE 7/7*
220-230V Plug

IPX-0

230 V.A.C. — 50/60 Hz, 1 ph
0.6 kW, 2.6 Amps
Type B Equipment



BS 1363 Plug*
(UK only)
CEE 7/7*
220-230V Plug



EC350

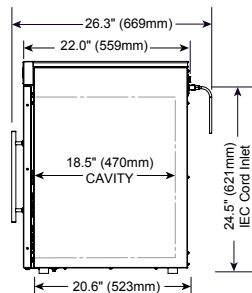
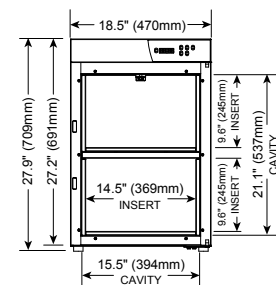
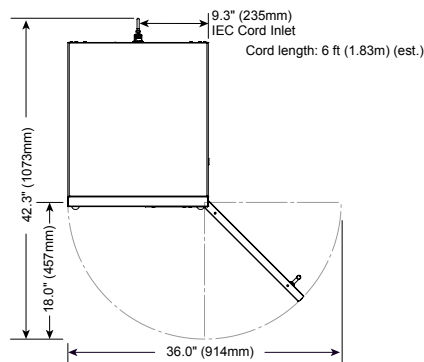

Dimensions (HxWxD)

With feet (STANDARD):	27.9" x 18.5" x 26.3" (709mm x 470mm x 669mm)
With casters & plate (OPTIONAL):	32.2" x 18.5" x 26.3" (818mm x 470mm x 669mm)
With bumper and casters (OPTIONAL):	32.2" x 21.3" x 26.5" (818mm x 540mm x 674mm)
With casters (OPTIONAL):	31.5" x 18.5" x 26.3" (799mm x 470mm x 669mm)

Capacity 3.5 ft³

Weight (est.)** NET 91 lbs (41 kg) SHIP, CRATED 143 lbs (65 kg)

Electrical

120 V.A.C. — 60 Hz, 1 ph
0.8 kW, 6.7 Amps
Safety Class I Equipment
No Applied Parts
Mode of Operation: Continuous



NEMA 5-15P
15A - 125V Plug
Hospital Grade



220 V.A.C. — 50 Hz, 1 ph
0.8 kW, 3.6 Amps
Type B Equipment



CEE 7/7*
220-230V Plug

IPX-0

230 V.A.C. — 50/60 Hz, 1 ph
0.8 kW, 3.5 Amps
Type B Equipment



BS 1363 Plug*
(UK only)



CEE 7/7*
220-230V Plug

*Other international plugs are available. Contact factory for more information.

**Domestic ground shipping information. Contact factory for export weight and dimensions.

EC Series Blanket Warming Cabinet

EC750

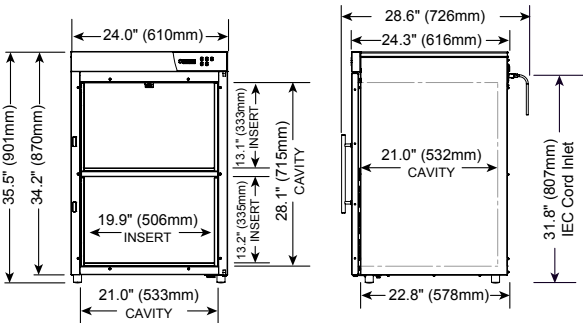
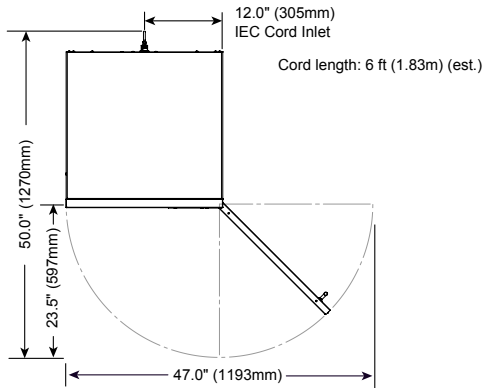

Dimensions (HxWxD)



With feet (STANDARD):	35.5" x 24.0" x 28.6" (901mm x 610mm x 726mm)
With casters & plate (OPTIONAL):	39.3" x 24.0" x 28.6" (998mm x 610mm x 726mm)
With bumper and casters (OPTIONAL):	39.3" x 26.8" x 28.8" (998mm x 679mm x 732mm)
With casters (OPTIONAL):	40.7" x 24.8" x 28.6" (1033mm x 631mm x 726mm)

Capacity 7.5 ft³

Weight** (est.) NET 134 lbs (61 kg) SHIP, CRATED 219 lbs (99 kg)

Electrical



120 V.A.C. — 60 Hz, 1 ph
0.8 kW, 6.7 Amps
Safety Class I Equipment
No Applied Parts
Mode of Operation: Continuous

 NEMA 5-15P
15A - 125V Plug
Hospital Grade  IPX-0

220 V.A.C. — 50 Hz, 1 ph
0.8 kW, 3.6 Amps
Type B Equipment

 CEE 7/7* IPX-0
220-230V Plug

230 V.A.C. — 50/60 Hz, 1 ph
0.8 kW, 3.5 Amps
Type B Equipment

 BS 1363 Plug* (UK only)  IPX-0
 CEE 7/7* 220-230V Plug

*Other international plugs are available. Contact factory for more information.

**Domestic ground shipping information. Contact factory for export weight and dimensions.



ENTHERMICS MEDICAL SYSTEMS

An ISO 13485:2003 certified company

PO Box 443, Menomonee Falls WI 53052-0443
W164 N9221 Water St, Menomonee Falls WI 53051
Tel 262-251-8356 | 800-TO-B-WARM
generalinfo@enthermics.com
www.enthermics.com